

**REINHOLD ENVIRONMENTAL Ltd.**



**2013 APC Round Table  
& Expo Presentation**

**July 8-9, 2013, in St. Louis, MO / Hosted by Ameren**

All presentations posted on this website are copyrighted by Reinhold Environmental, Ltd (RE). Any unauthorized downloading, attempts to modify or to incorporate into other presentations, link to other websites, or obtain copies for any other uses than the training of attendees to RE's Conferences is expressly prohibited, unless approved in writing by RE or the original presenter. RE does not assume any liability for the accuracy or contents of any materials contained in this library which were presented and/or created by persons who were not employees of RE.

# MATS Monitoring

Scott Evans



# MATS HAPS

## Pollutant of Concern

Mercury

Non-Hg metallic HAPs

Acid gas HAPs

Organic HAPs

## Monitoring Surrogate

Mercury

Filterable Particulate

HCl/SO<sub>2</sub>/Moisture

Work Practice (Tuneups)

Note: Liquid Fuel units do not have an Hg limit separate from other metallic HAPs

# Key MATS Dates

February 16, 2012 - Final Rule

April 24, 2013 - Reconsideration #1  
New Units - Final Rule

June 25, 2013 - Reconsideration #2  
Startup/Shutdown - Reopen comment period

# February 16, 2012 - Final Rule

## Establishes...

Pollutants of concern

Surrogate compounds

Emission limits for both new and existing units

Averaging periods

Monitoring methods/technologies

# Key MATS Dates

February 16, 2012 - Final Rule

April 24, 2013 - Reconsideration #1

New Units - Final Rule

June 25, 2013 - Reconsideration #2

Startup/Shutdown - Reopen comment period

# April 24, 2013 - Reconsideration #1

New Units - Final Rule

## Changes...

Emission limits for new units

## Establishes...

Procedure for calculating CPMS compliance parameter for new units

Clarifies Hg sorbent tube detection limits for short runs

PM CPMS exceedance procedures and presumptive violations

# Key MATS Dates

February 16, 2012 - Final Rule

April 24, 2013 - Reconsideration #1

New Units - Final Rule

June 25, 2013 - Reconsideration #2

Startup/Shutdown - Reopen comment period

# June 25, 2013 - Reconsideration #2

Startup/Shutdown - Reopen comment period

## Inviting comments on...

Use of sorbent traps during startup and shutdown

Whether to allow use of diluent cap for non-Hg pollutants

# MATS Emission Limit Comparison

		PM (lb/MWh)		HCl (lb/MWh)		Hg (lb/GWh)		HF (lb/MWh)	
		Final Rule		Final Rule		Final Rule		Final Rule	
<b>Existing</b>	NLR	0.30		0.020		0.0130		--	
	LR	0.30		0.020		0.120*		--	
	IGCC	0.40		0.0050		0.030		--	
	SO	0.090		0.080		0.0020		--	
	LO-C	0.30		0.010		--		0.0040	
	LO-NC	0.30		0.0020		--		0.00050	
		PM (lb/MWh)		HCl (lb/MWh)		Hg (lb/GWh)		HF (lb/MWh)	
		Final Rule	Recons.	Final Rule	Recons.	Final Rule	Recons.	Final Rule	Recons.
<b>New</b>	NLR	0.0070	0.090	0.00040	0.010	0.00020	0.0030	--	--
	LR	0.0070	0.090	0.00040	0.010	0.040	NR	--	--
	IGCC-SG	0.070	0.070	0.0020	0.0020	0.0030	0.0030	--	--
	IGCC-NG	0.090	0.090	0.0020	0.0020	0.0030	0.0030	--	--
	SO	0.020	0.030	0.00040	NR	0.0020	NR	--	--
	LO-C	0.070	0.30	0.00040	NR	--	--	0.00040	NR
	LO-NC	0.20	0.20	0.0020	NR	--	--	0.00050	NR

NR = Not Reconsidered

\* Beyond the floor limit for LR w/ACI = 0.04

# PM Emissions Monitoring

# Monitoring Options

Continuous Emission Monitoring (CEMS)

Continuous Parameter Monitoring (CPMS)

Periodic Stack Test

Existing Units Only

# Monitoring Options

Continuous Emission Monitoring (CEMS)

Continuous Parameter Monitoring (CPMS)

Periodic Stack Test

Existing Units Only

# PM CEMS General Issues

Uncertainty regarding long term reliability over a wide range of PM characteristics and operating conditions

Obtaining valid PM correlations especially in wet stacks

Particulate stratification

# CEMS Technology Options

## Beta Attenuation

MSI

Durag

Altech

## Light Scattering

Durag

Sick

M&C

PCME

Teledyne

## Hybrid

Thermo

# CEMS Technology Options

## Beta Attenuation

Example shown is MSI Betaguard

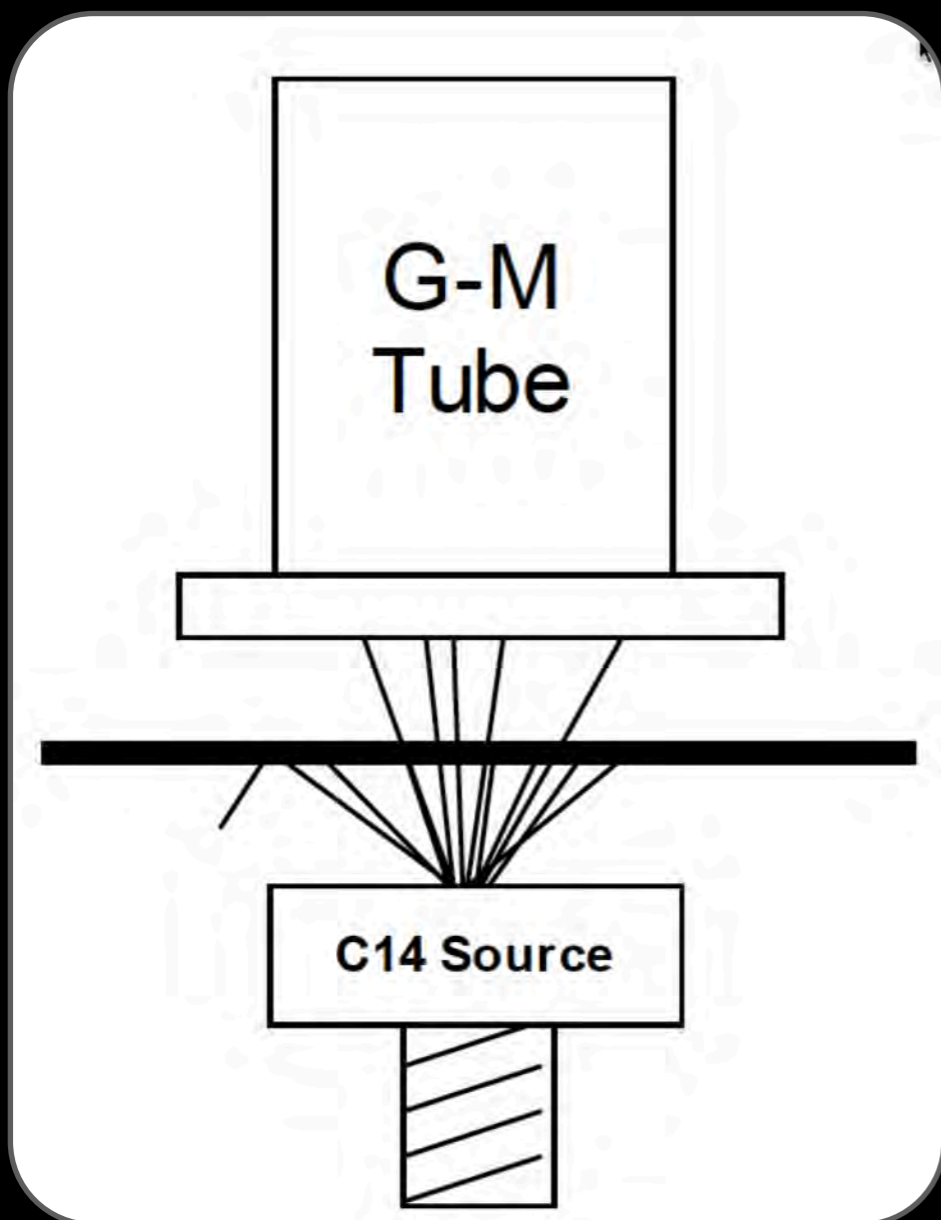

Mass is correlated to attenuation of beta particles (electrons/positrons) on blank filter vs loaded filter

# CEMS Technology Options

## Beta Attenuation

### Advantages

- Less affected by particulate characteristics

- Large installed base

- Proven technology - able to pass PS II cert

### Disadvantages

- Long response time (1-5 data points per hour)

- Extractive sampling

- High initial capital cost/High on-going cost

- Less sensitive at lower concentrations

# CEMS Technology Options

## Beta Attenuation

**Sensitivity**      **0.0003 gr/dscf**  
12.5 minute sample at 1:1 dilution ratio

Source: Clapsaddle, *BetaGuard PM Particulate Monitor Discussion*, MARMA Webinar, 2011

# CEMS Technology Options

## Beta Attenuation Monitoring Costs<sup>a</sup>

	Type	EPA Estimate <sup>b</sup>	Reality <sup>c</sup>
Capital Costs	CEMS	\$190,000	\$250-400,000
	CPMS	\$190,000	\$250-400,000
Ongoing Costs <sup>d</sup>	CEMS	\$40,000	\$40-80,000
	CPMS	\$32,000	\$35-50,000

<sup>a</sup> Costs do not include stack or platform modifications.

<sup>b</sup> From EPA CEMS Cost Model 03/07/07 w/ 10% inflation adjustment to 2012

<sup>c</sup> Vendor and user information (rough estimates based on limited data)

<sup>d</sup> Annual Costs. Without capital recovery. Assuming annual RCA.

# CEMS Technology Options

## Beta Attenuation

MSI

Durag

Altech

## Light Scattering

Durag

Sick

M&C

PCME

Teledyne

## Hybrid

Thermo

# CEMS Technology Options

## Light Scattering

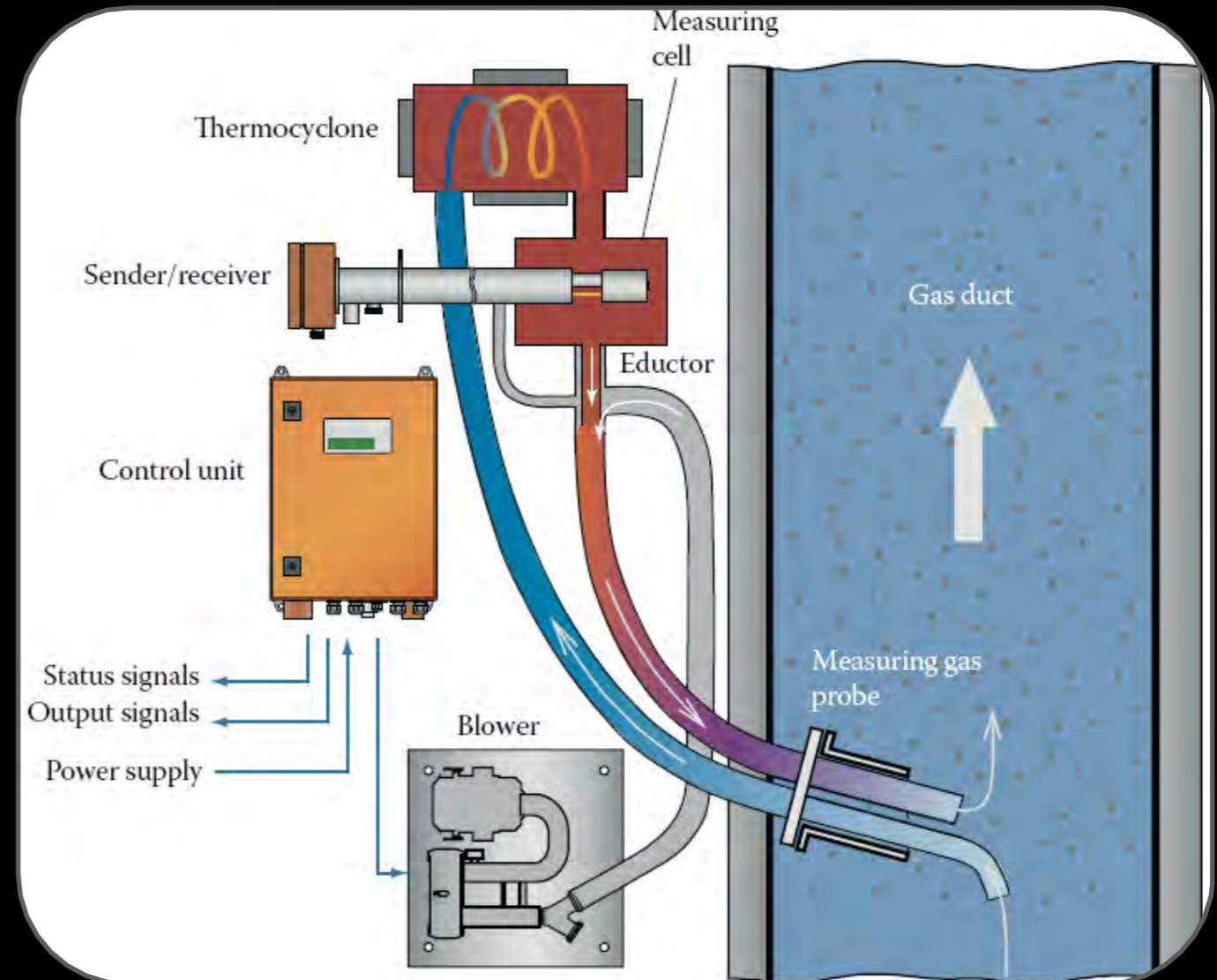
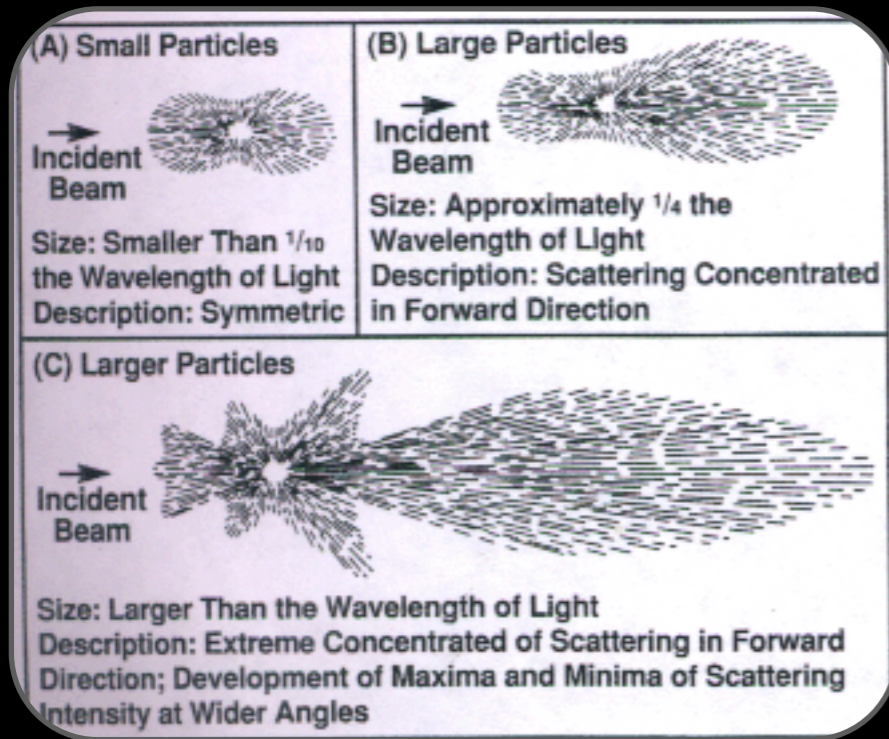

Illustration from: *EPM CEMS In Wet Stacks - E.ON US Operating Experience*

# CEMS Technology Options

## Light Scattering

### Advantages

- Lower initial capital cost/Lower on-going costs

- In-situ sensor available for dry stacks

- Higher sensitivity at lower PM concentrations

- “Real time” data

### Disadvantages

- More affected by particulate characteristics

- Extractive sampling still needed for wet stacks

- Not as well established as beta attenuation technology

# CEMS Technology Options

## Light Scatter Monitoring Costs<sup>a</sup>

	Type	EPA Estimate <sup>b</sup>	Reality <sup>c</sup>
Capital Costs	CEMS	\$150,000	\$150-300,000
	CPMS	\$150,000	\$150-300,000
Ongoing Costs <sup>d</sup>	CEMS	\$75,000	\$---
	CPMS	\$---	\$---

<sup>a</sup> Costs do not include stack or platform modifications.

<sup>b</sup> From EPA "Current Knowledge of Particulate Matter Continuous Emission Monitoring" w/ 32% inflation adjustment to 2012

<sup>c</sup> Vendor and user information (rough estimates based on limited data)

<sup>d</sup> Annual Costs. Without capital recovery. Assuming annual RCA

# CEMS Technology Options

## Light Scattering

**Sensitivity**      **Back scatter 0.0005 - 8 gr/dscf**  
**Forward scatter 0.006 - 1 gr/dscf**

Source: Eiseman, *Monitoring for Fine Particulate Matter*, Critical Technologies Institute, 1998

# CEMS Technology Options

## Beta Attenuation

MSI

Durag

Altech

## Light Scattering

Durag

Sick

M&C

PCME

Teledyne

## Hybrid

Thermo

# CEMS Technology Options

Hybrid

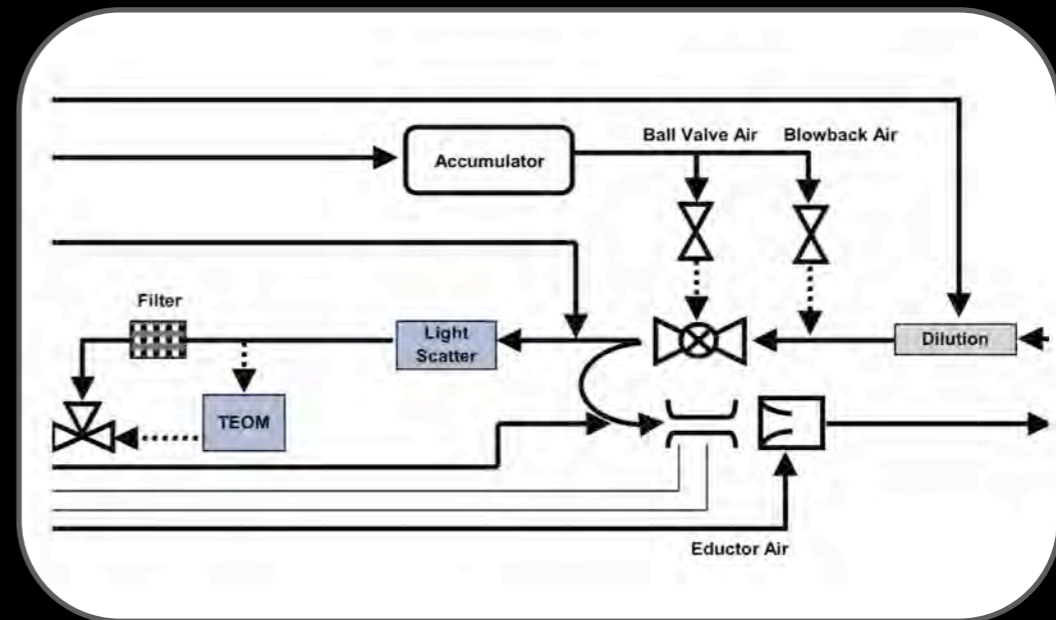

Potentially overcomes weaknesses of both light scatter and beta attenuation

# CEMS Technology Options

## Hybrid

### Advantages

- Fast response

- Calibrated directly to PM mass via TEOM

- Higher sensitivity at lower PM concentrations

- Uses both forward and back scatter to detect changes in PM characteristics

### Disadvantages

- Not commercially available

- Extractive sampling

# CEMS Technology Options

Hybrid

Sensitivity

Cost

???

# Certification QA/QC

40 CFR 60  
Appendix B  
Performance Specification I I

40 CFR 60  
Appendix F  
Procedure 2

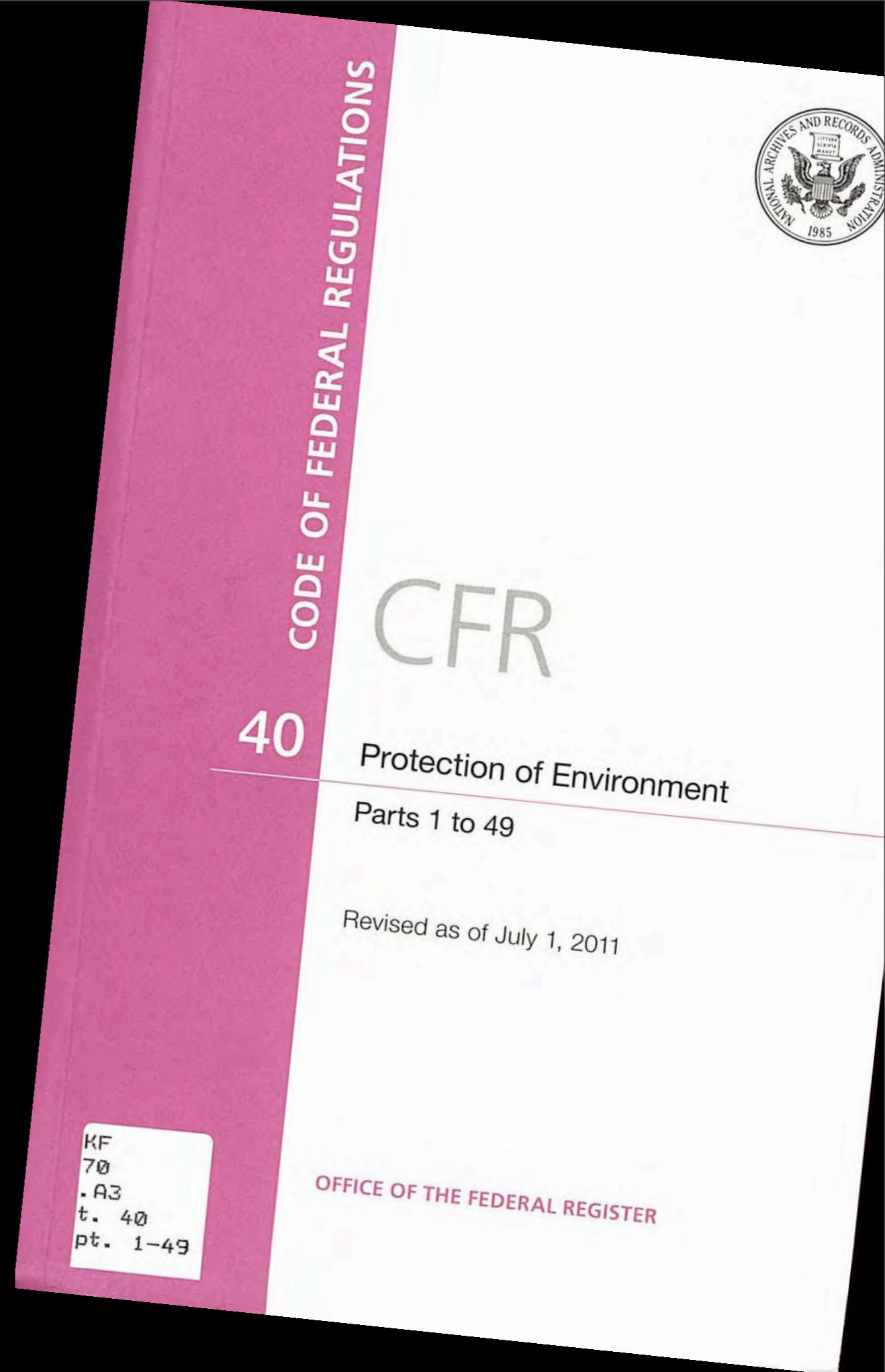

# Certification

## Performance Specification II

Minimum 4 data points per hour

7-day drift test

Correlation Test instead of RATA

# Certification

## Performance Specification II

### Correlation Test

15 test runs - More usually required

At least 20 minutes per run

Method 5, 5D only - No M17, 5i

Three PM levels

TEOM can substitute for Method 5

# Certification

## Performance Specification II

### Approaches to Varying PM Concentration

Vary process operating conditions

Vary control device operating conditions

PM Spiking

# PM Spiking Techniques

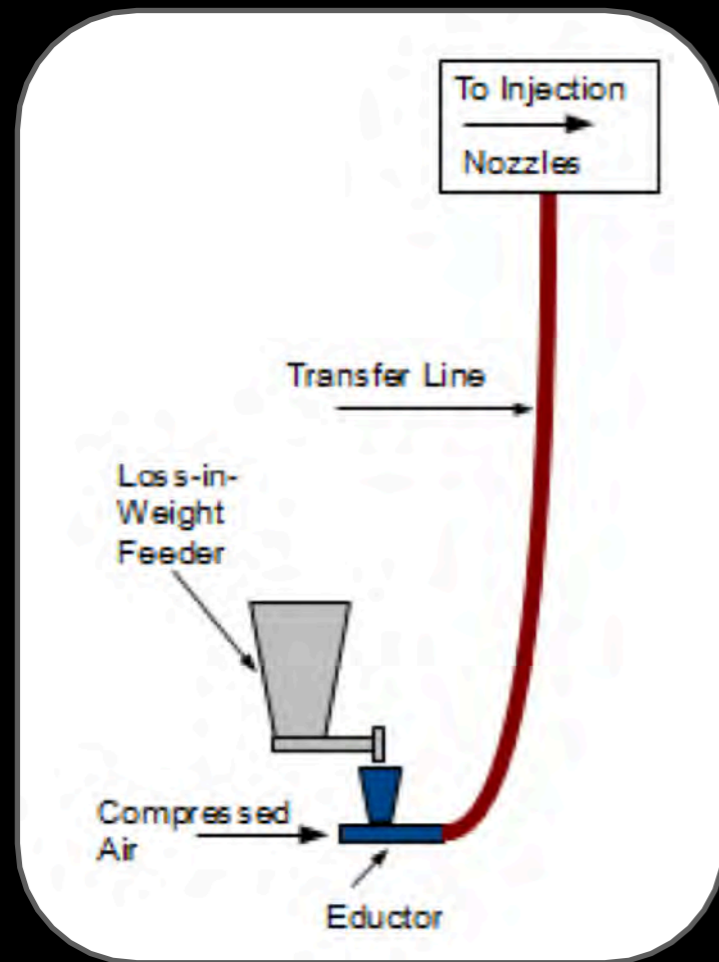

## Ash Reinjection B3 Systems



## Quantitative Aerosol Generator (QAG) Cooper Environmental Services

# PM Spiking Issues

Does spiking provide a representative particle size distribution?

Does a spiked correlation equal a PS II correlation?

Does injection of spiked particulate create stratification?

EPRI QAG test program - PS II revision?

# Certification

## Performance Specification II

### Reduce Method Error

#### Probe and Filter Temperature

Range, Location, Stability

#### Acetone weights

Low tare weight containers

#### Constant Sample Weight

Range

#### Isokinetics

Range, Pitot Coefficient

#### Sampling Rate

Increase to 1.0 cfm

#### Materials

Require glass probe liner and nozzle

Source: Clapsaddle, EPRI CEMS 2013

# Certification

## Performance Specification II

### Reduce Human Error

#### Glassware

Rinse liner before use  
Use proof blanks

#### Wash brushes

New brushes every run

#### Rinse volume

Consistent for every run

#### Experienced testers

Attention to detail  
Consistent sampling train operation

Source: Clapsaddle, EPRI CEMS 2013

# QA/QC

## Appendix F, Procedure 2

### Daily Checks

#### Zero and upscale drifts

Difference  $< 4\%$  for any 5 days or  $< 8\%$  for any one day

#### Sample volume check - Extractive

Difference  $< 10\%$  for any 5 days or  $< 20\%$  for any one day

#### Optics check - Light scattering

# QA/QC

## Appendix F, Procedure 2

### Quarterly Checks

#### Absolute Correlation Audit (ACA)

Challenge 3 levels with audit reference

Difference  $< 10\%$  of audit value or  $< 7.5\%$  of standard whichever is greater

#### Sample Volume Audit (SVA)

Extractive systems only

Independent measure of sample volume extracted from the stack

3 runs  $\times$  20 minutes each

Difference  $< 5\%$  of sample audit volume

# QA/QC

## Appendix F, Procedure 2

### Annual Check

#### Relative Response Audit (RRA)

Once each year

3 Runs - As found operating condition

Max RRA data  $\leq$  Max correlation data

2/3 RRA data points must lie within correlation range

2/3 of RRA data points must lie within 25% emission limit from correlation curve

# QA/QC

## Appendix F, Procedure 2

### 3-year Check

#### Response Correlation Audit (RCA)

12 runs - 3 PM levels

Max PM CEMS RCA data  $\leq$  Max PM CEMS correlation data

9/12 RCA data sets must lie within correlation range

75% of RCA data sets must lie within 25% emission limit from correlation curve

# Monitoring Options

Continuous Emission Monitoring (CEMS)

Continuous Parameter Monitoring (CPMS)

Periodic Stack Test

Existing Units Only

# Monitoring Options

Continuous Emission Monitoring (CEMS)

Continuous Parameter Monitoring (CPMS)

Periodic Stack Test

Existing Units Only

# CPMS Technology Options



PM CEMS Example



PM CPMS Example

# CPMS Analysis

## Potential Advantages

- No PS II correlation
- No PS II QA/QC

## Potential Disadvantages

- Site specific operating limit
- Possibility of additional stack tests
- Presumptive violations
- Limit may change annually

# CPMS Operating Limit

## Establishing site specific operating limit

Conduct a typical 3-run stack test at normal load

Operating limit is highest 1-hour CPMS average during performance test

Conduct additional tests at other conditions if a different site specific operating limit is desired at these conditions

Re-establish limit annually

# CPMS Operating Limit

## Exceedances

Exceedances of the limit require a stack test within 45 days

Regardless of the outcome of the stack tests, more than 4 required stack tests within a 12 month period is considered a presumptive violation of the standard

# Monitoring Options

Continuous Emission Monitoring (CEMS)

Continuous Parameter Monitoring (CPMS)

Periodic Stack Test

Existing Units Only

# Monitoring Options

Continuous Emission Monitoring (CEMS)

Continuous Parameter Monitoring (CPMS)

**Periodic Stack Test**

Existing Units Only

# Periodic Monitoring

## Advantages

- No capital expenditures

- No equipment maintenance/repair

## Disadvantages

- You give up a certain degree of control

- Variability of stack tests tends to be greater than variability of continuous monitoring

- If you fail, longer non-compliance period

# Periodic Monitoring

Quarterly stack testing

Method 5, 5D only

Method 5 probe and filter temp raised to 320 °F

# Periodic Monitoring

## Estimated Stack Test Costs

Test	Approximate Cost
Filterable PM (M5, M5D)	\$7,600 - 11,400
HAPs Metals (M29)	\$12,400 - 18,600
PM CEMS RATA (PSI I)	\$18,000 - 26,000

Note: Prices are for individual tests at a single location assuming no delays. Simultaneous testing with multiple methods may reduce overall costs. Actual testing costs will vary from these estimates based on site-specific conditions, variable travel costs, and current market conditions.

# Periodic Monitoring

Interesting comparison...

Annual cost of quarterly stack tests: ~\$40,000

Annual operating cost of PM CEMS: ~\$40,000

The background features a dark purple and green color scheme with a textured, halftone-like pattern. Large, stylized letters 'E' and 'G' are visible in the background, with the 'E' in purple and the 'G' in green. The text 'Mercury Emissions Monitoring' is centered in white.

# Mercury Emissions Monitoring

# CEMS Technology Options

## Sorbent Tube

CleanAir

Apex

Altech

M&C

## CEMS

Thermo

Tekran

Ohio Lumex

PS Analytical

Sick

Durag

Cemtrex

Nippon

Opsis

# CEMS Technology Options

## CEMS Advantages

Real-time

No additional analysis

Startup/Shutdown

## Sorbent Traps Advantages

Lower cost - initial and ongoing

Simple

Very low concentrations

Simpler certification

Reliability

# Monitoring Options

Continuous Emission Monitoring (CEMS)

Sorbent Tube Monitoring

# Monitoring Options

Continuous Emission Monitoring (CEMS)

Sorbent Tube Monitoring

# CEMS Technology

## Calibration

### Elemental $\text{Hg}^0$ calibration gas

Head-space Hg gas generator

Hg cylinder gas

Permeation source

### Oxidized $\text{Hg}^{2+}$ calibration gas

Evaporative generators

Conversion generators



Model 2537A CVAFS Analyzer

Model 3310 Hg<sup>0</sup> calibrator

Model 3315 Hg<sup>II</sup> calibrator

Model 3320 Sample Conditioner

Source: Tekran Instruments, Inc.

Source: Martin, EPRI CEMS 2013

# CEMS Technology

## Calibration

Elemental Hg Interim Protocol  
Oxidized Hg Interim Protocol

EPA Issued “Final” Interim  
Protocol in July 2009

Only applies to spans  $> 5\mu\text{g}/\text{m}^3$   
MATS limit  $\sim 1.2\mu\text{g}/\text{m}^3$



Model 2537A CVAFS  
Analyzer

Model 3310 Hg0  
calibrator

Model 3315 HgII  
calibrator

Model 3320 Sample  
Conditioner

Source: Tekran Instruments, Inc.

Source: Martin, EPRI CEMS 2013

# Monitoring Options

Continuous Emission Monitoring (CEMS)

Sorbent Tube Monitoring

# Monitoring Options

Continuous Emission Monitoring (CEMS)

Sorbent Tube Monitoring

# Sorbent Trap Technology



Images Clean Air Engineering

# Sorbent Trap Technology

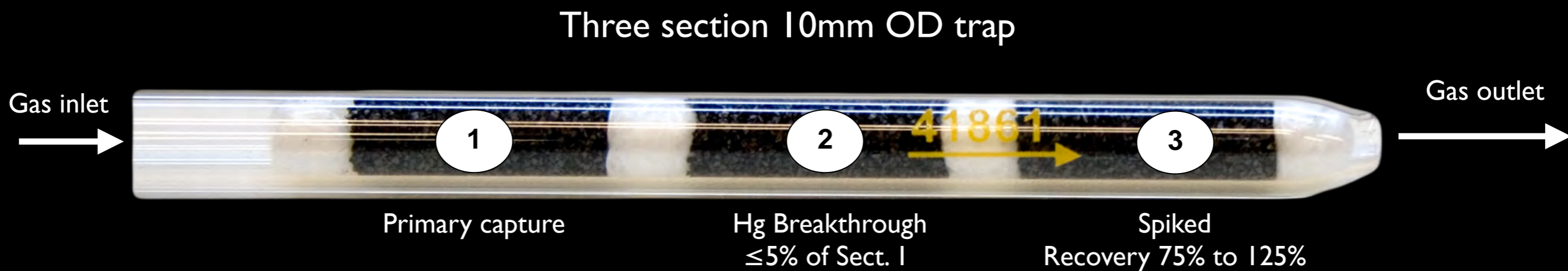

Images Courtesy Ohio Lumex

# Sorbent Trap Technology

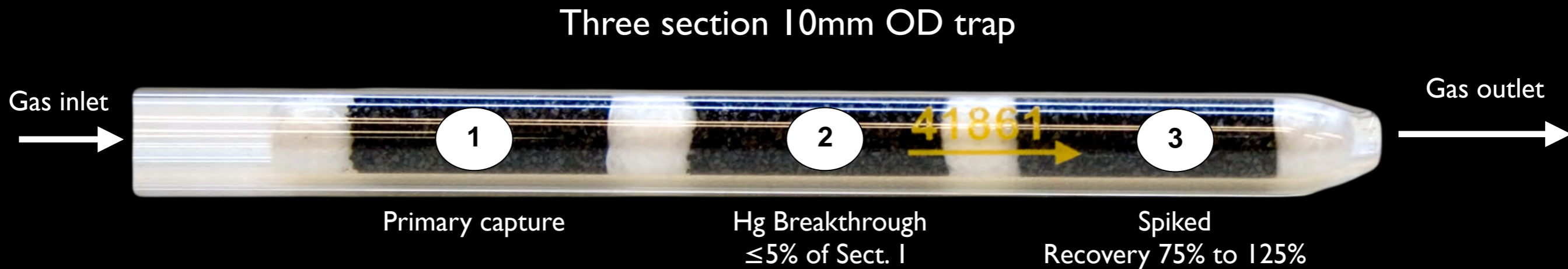

## Speciated Hg Trap

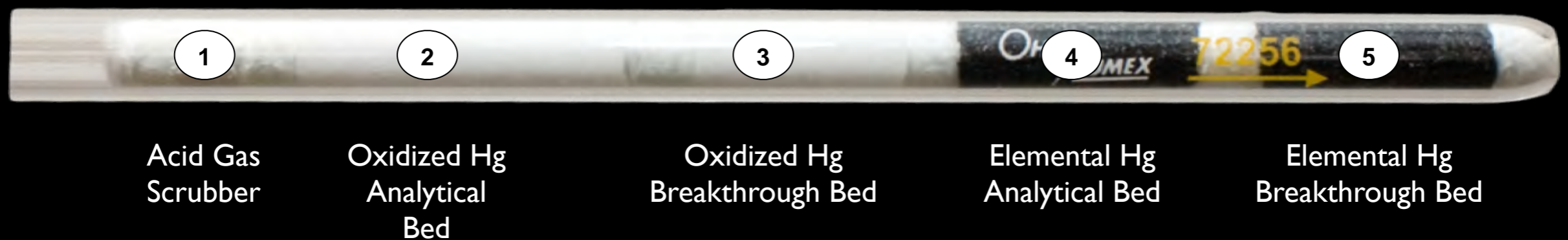

Images Courtesy Ohio Lumex

# Sorbent Trap Technology

Sorbent traps should be customized to the specific flue gas characteristics found at the source

Hg level

Moisture

Acid gas fraction



Images Courtesy Ohio Lumex

# Sorbent Trap Technology



Differential Atomic Absorption Spectrometer

Images Courtesy Ohio Lumex

# Hg Hybrid Approach

Sorbent traps for compliance

Hg CEMS for process control



CleanAir MET-80 STMS

Tekran Hg CEMS

# CEMS Technology Options

## Hg Monitoring Costs<sup>a</sup>

	Type	EPA Estimate <sup>b</sup>	Reality <sup>c</sup>
Capital Costs	CEMS	\$220,000	\$300-400,000
	Sorbent trap	N/A	\$100-150,000
Ongoing Costs <sup>d</sup>	CEMS	\$77,000	\$50-75,000
	Sorbent trap	N/A	\$20-30,000

<sup>a</sup> Costs do not include stack or platform modifications

<sup>b</sup> From EPA CEMS Cost Model 03/07/07 w/ 10% inflation adjustment to 2012

<sup>c</sup> Vendor information

<sup>d</sup> Annual Costs. Without capital recovery

# Monitoring Options

Special Consideration for Hg LEE monitoring

Method 30B each year

## Sampling Location

Within 10% of centroidal area

## Test Run Duration

Up to 10 days per run

## Moisture Determination

Method 4

Default

ALT-091

Source: Roberson, EPRI CEMS 2013

# Certification

40 CFR 60

Appendix B

Performance Specification 12A  
CEMS

Performance Specification 12B  
Sorbent Traps

40 CFR 60

Appendix A

Subpart UUUUU

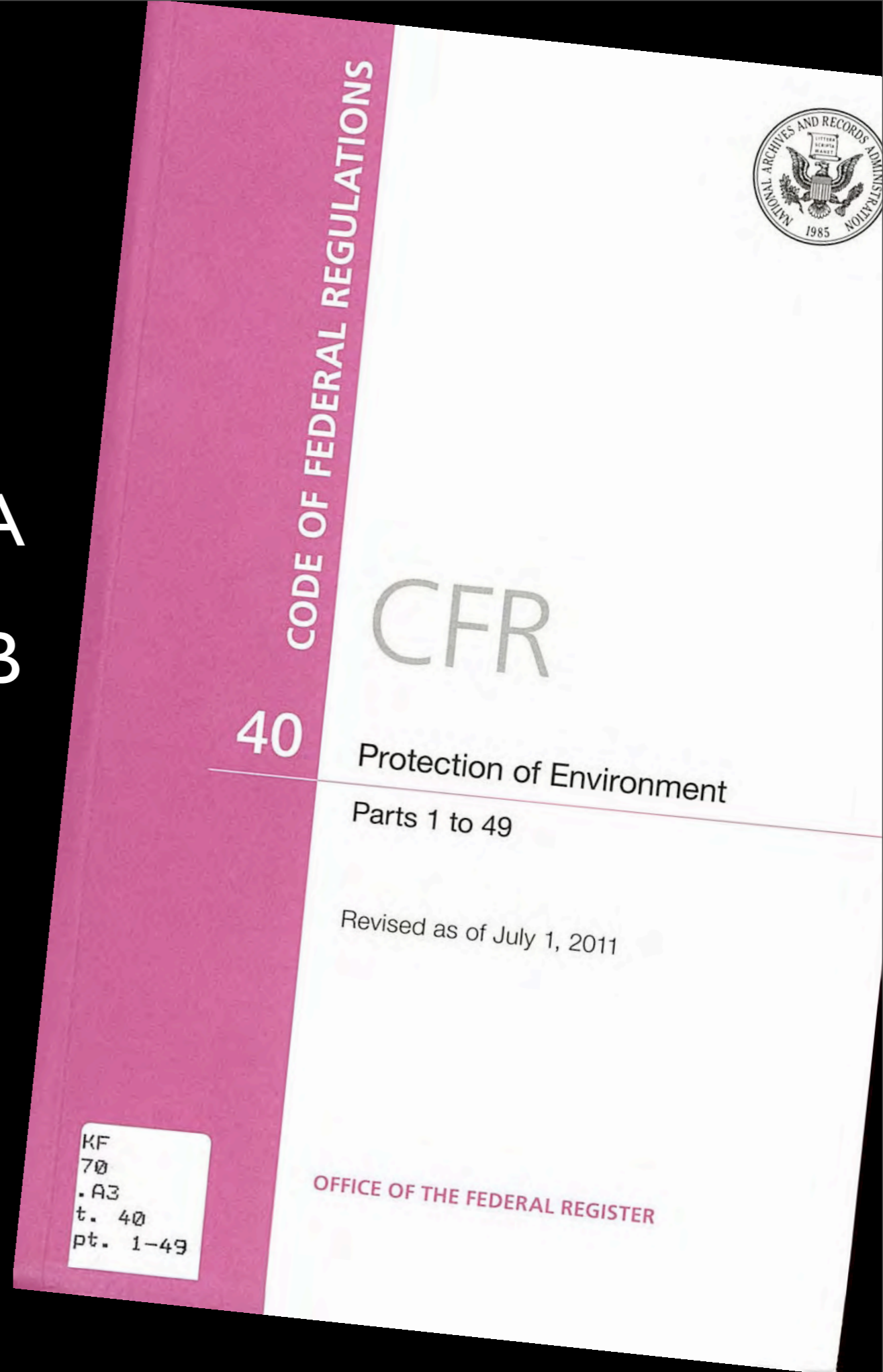

# Initial Certification

## Mercury CEMS

7-Day Cal Error Test

Linearity Check

System Integrity Check

Cycle Time Test

Relative Accuracy Test Audit

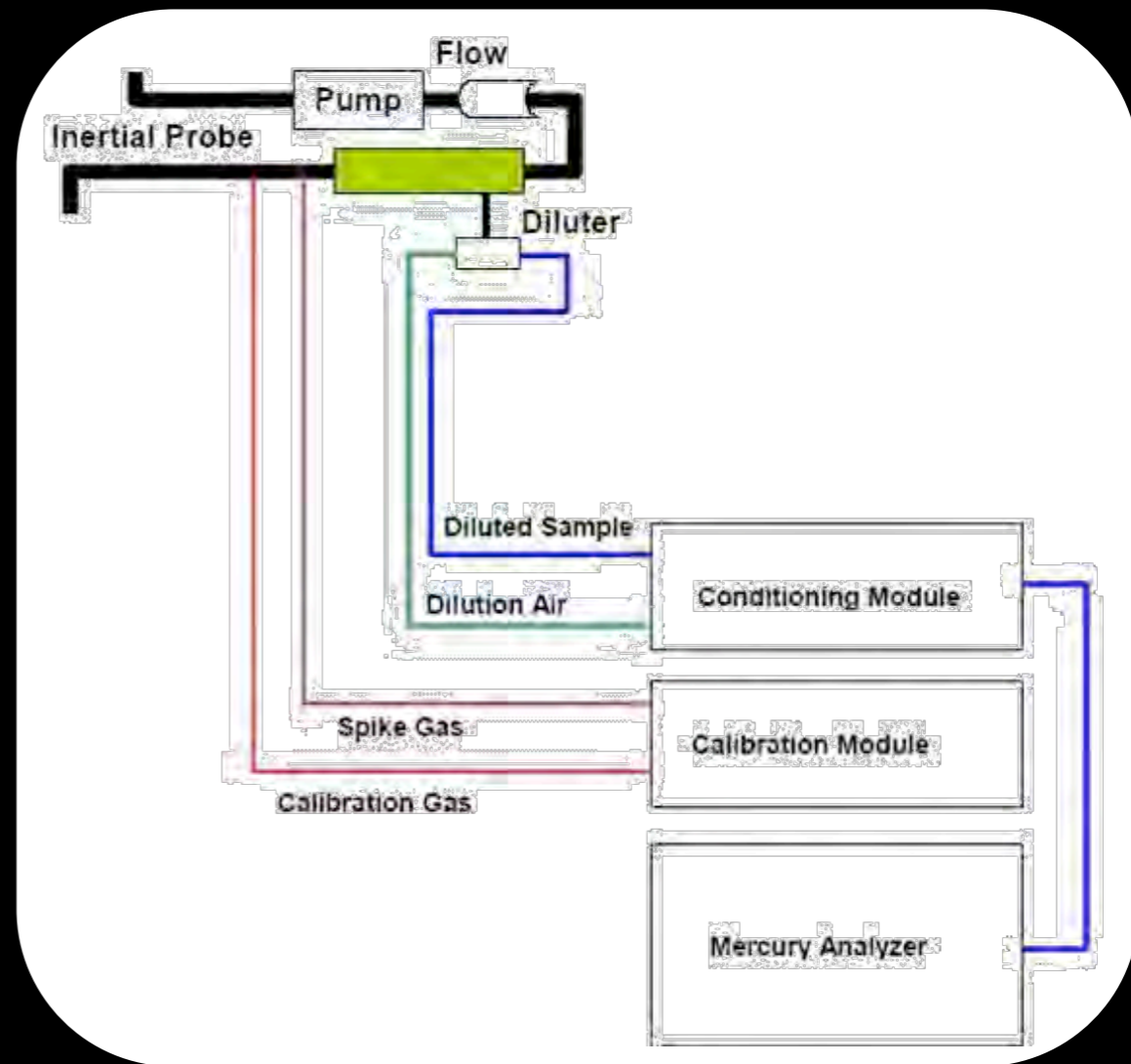

Source: Electric Power Research Institute

# Initial Certification



## Sorbent Trap MMS

Calibration of meters & sensors

Relative Accuracy Test Audit

# Ongoing QA/QC

## Mercury CEMS

Daily Calibration Error

Weekly System Integrity Check

Quarterly Linearity/Integrity Check

Annual RATA



## Sorbent Trap MMS

Trap exchanges (14 days max)

Laboratory Analysis

Annual RATA



Source: Tekran Instruments, Inc.

# Periodic Monitoring

## Estimated Stack Test Costs

Test	Approximate Cost
Hg by M29 (paired trains)	\$18,400 - 24,600
Hg (M30B - 30 days)	\$15,200 - 23,400

Note: Prices are for individual tests at a single location assuming no delays. Simultaneous testing with multiple methods may reduce overall costs. Actual testing costs will vary from these estimates based on site-specific conditions, variable travel costs, and current market conditions.

The background features large, stylized letters 'H', 'C', and 'L' in a vibrant green and purple color. The letters are filled with a fine, grainy texture and are set against a solid black background. The 'H' is on the left, the 'C' is in the center, and the 'L' is on the right. The text 'HCl Emissions Monitoring' is overlaid in white, sans-serif font across the middle of the image.

# HCl Emissions Monitoring

# Monitoring Options

Continuous Emission Monitoring (CEMS)

Periodic Stack Test

Existing Units Only

# Monitoring Options

Continuous Emission Monitoring (CEMS)

Periodic Stack Test

Existing Units Only

# HCI CEMS General Issues

Lack of technology-neutral Performance Specification

Currently being addressed by EPA

Performance Specification 18

Emission limits vs technology capability

Limits at or near instrument LOD

Low-level calibration gas stability

# HCI Technology Options

## FTIR

IMACC

Thermo

MKS

ABB

## TDL

CEMTEK

OPSIS

Sick

Siemens

Yokogawa

Ametek

## CRDS

Tiger Optics

Los Gatos

Picarro

## GFC

Thermo

Environment-SA

Altech

## NDIR

Cosa-Xentaur

# HCl Technology Options

HCl CEMS Study at Cement Plants  
3 ppm HCl limit

Met study requirements

Thermo Scientific OMNI FTIR CEMS  
CEMTEK/Unisearch TDL (cross-stack)

Did not meet study requirements

ABB ACF-NT FTIR CEMS  
SICK MCS100E (IR multi-parameter)

Source: Peeler, EPRI CEMS 2013

# HCl CEMS Issues

## Calibration Issues

Existing NLR Unit HCl Limit

0.020 lb/MWh  $\approx$  1.3 ppmwv

Span is defined as 2x the emission limit (PS18)

This means the **span** of the HCl CEMS is

2.6 ppm let's say **3 ppm**

# HCl CEMS Issues

## Calibration Issues

Cal gases must be in the following ranges

Low - 10-30% of span --- 0.3 - 0.9 ppm

Mid - 30-50% of span --- 0.9 - 1.5 ppm

High - 80-120% of span --- 2.4 - 3.6 ppm

Gases must be EPA Protocol gases i.e.  $\pm 2\%$

For the highest high range gas, that's  $\pm 0.07$  ppm

# HCl CEMS Issues

## Calibration Issues

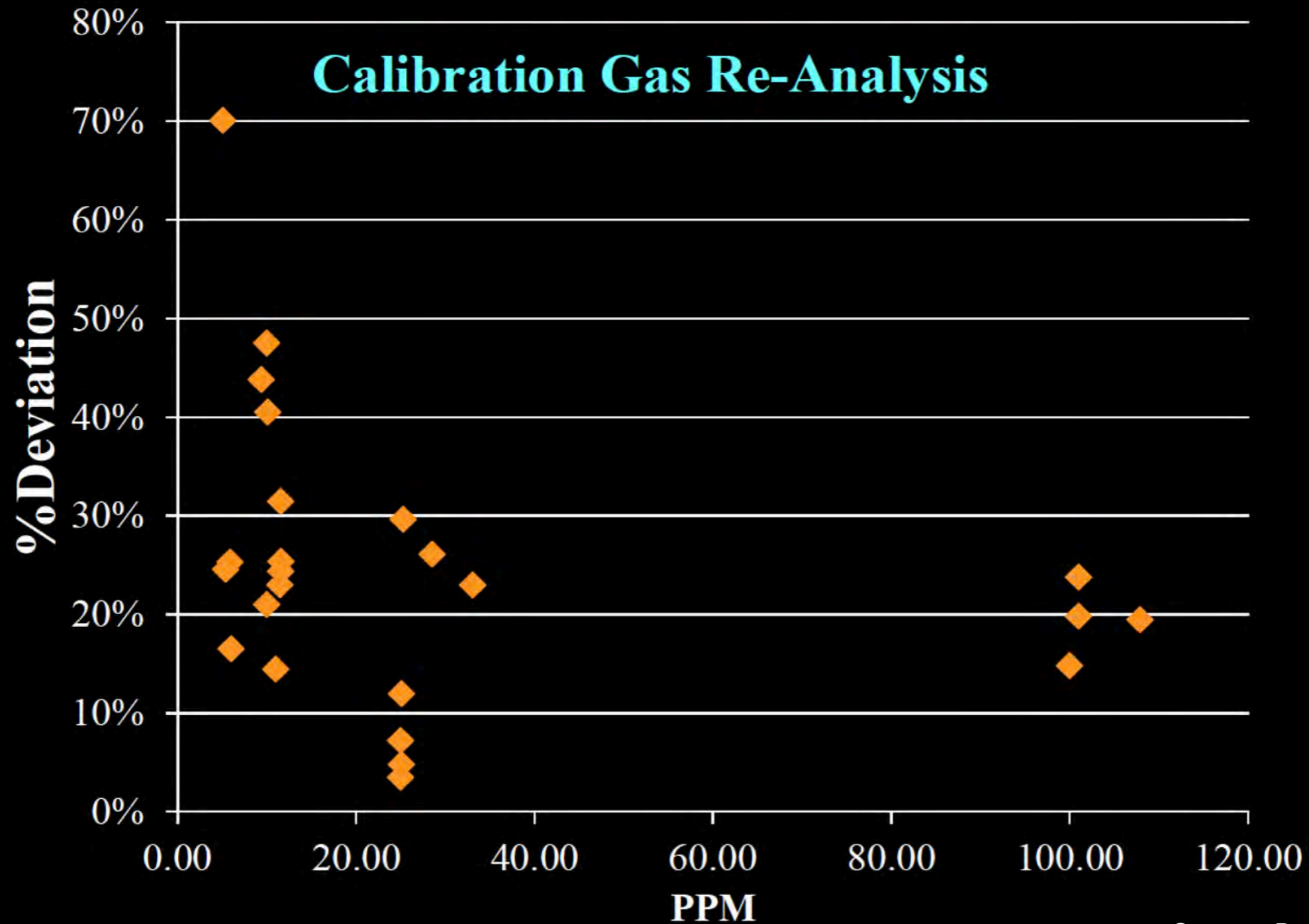

Source: Peeler, EPRI CEMS 2013

# HCl CEMS Issues

## Calibration Issues

### Peeler's Take on HCl Cal Gas Re-analysis...

Takes significant period to fully stabilize

Takes significant time to recover

All CEMS tested analyzed dry calibration gases without problems

Does not detect ammonium chloride salt formation, & adsorption/desorption

Does not reveal formaldehyde interference

Does little good

“Compressed gases used in this study are not ‘standards’ and of limited use for QA checks”

Source: Peeler, EPRI CEMS 2013

# HCl CEMS Issues

## Calibration Issues

HCl CEMS LOD must be  
< 20% of the limit

PS 18 §13.1.1

20% of 1.3 ppm = 0.26 ppm

Typically the Limit of Quantitation (LOQ) is 3 x LOD

3 x 0.26 = 0.78 ppm

A PS 18 acceptable HCl analyzer may not be  
able to reliably measure most low range  
calibration gas

# HCl CEMS Issues

## Calibration Issues

### Calibration Error (CE) and Calibration Drift (CD) Tests

CE and CD must be  $< 5\%$  of span

$$0.05 \times 3 \text{ ppm} = 0.15 \text{ ppm}$$

Remember... LOD = 0.26 ppm

A PSI 8 acceptable analyzer may not have the resolution to determine whether CE and CD tests were passed or failed.

# HCl CEMS Issues

## Certification Issues

### Relative Accuracy Test Audit

RA  $\leq$  20% or if mean RM  $<$  1.0 ppm then 0.2 ppm

Again... LOD is 0.26 ppm

LOQ is 0.78 ppm

# HCl CEMS Issues

## Certification Issues

To meet all of the PS 18 requirements  
the LOD can be no higher than

**0.05 ppm**

An order of magnitude lower than the current 0.26 ppm  
About 4% of limit

Is there a commercially available  
technology that can achieve this?

# HCI CEMS Issues

## Certification Issues

Dynamic spike alternative with **CRAS**

Calibration **R**ange **A**bove **S**pan

PS 18 first Performance Specification to allow dynamic spiking in lieu of RATA

CRAS allows higher concentration calibration gases

Helps with RATA only does not affect other issues

# HCI CEMS Issues

EPRI Testing

Just getting underway

CEMS being installed as we speak

OP SIS - TDL

Cemtek - TDL

Thermo - FTIR

Tiger Optics - CRDS

ABB - FTIR?

Data collection starts in July

Follows draft PS I 8 and Appendix F

# CEMS Technology Options

## HCl, HF, SO<sub>2</sub> Monitoring Costs<sup>a</sup>

	Type	EPA Estimate <sup>b</sup>	Reality <sup>c</sup>
Capital Costs	CEMS	\$160,000	\$100-200,000
Ongoing Costs <sup>d</sup>	CEMS	\$22,000	\$15-30,000

<sup>a</sup> Costs do not include stack or platform modifications. Costs are for a “typical” criteria pollutant and diluent system.

<sup>b</sup> From EPA CEMS Cost Model 03/07/07 w/ 10% inflation adjustment to 2012

<sup>c</sup> Vendor and user information (rough estimates based on limited data)

<sup>d</sup> Annual costs. Without capital recovery

# Certification

40 CFR 60

Appendix B

Performance Specification 18

40 CFR 60

Appendix F

Procedure 1

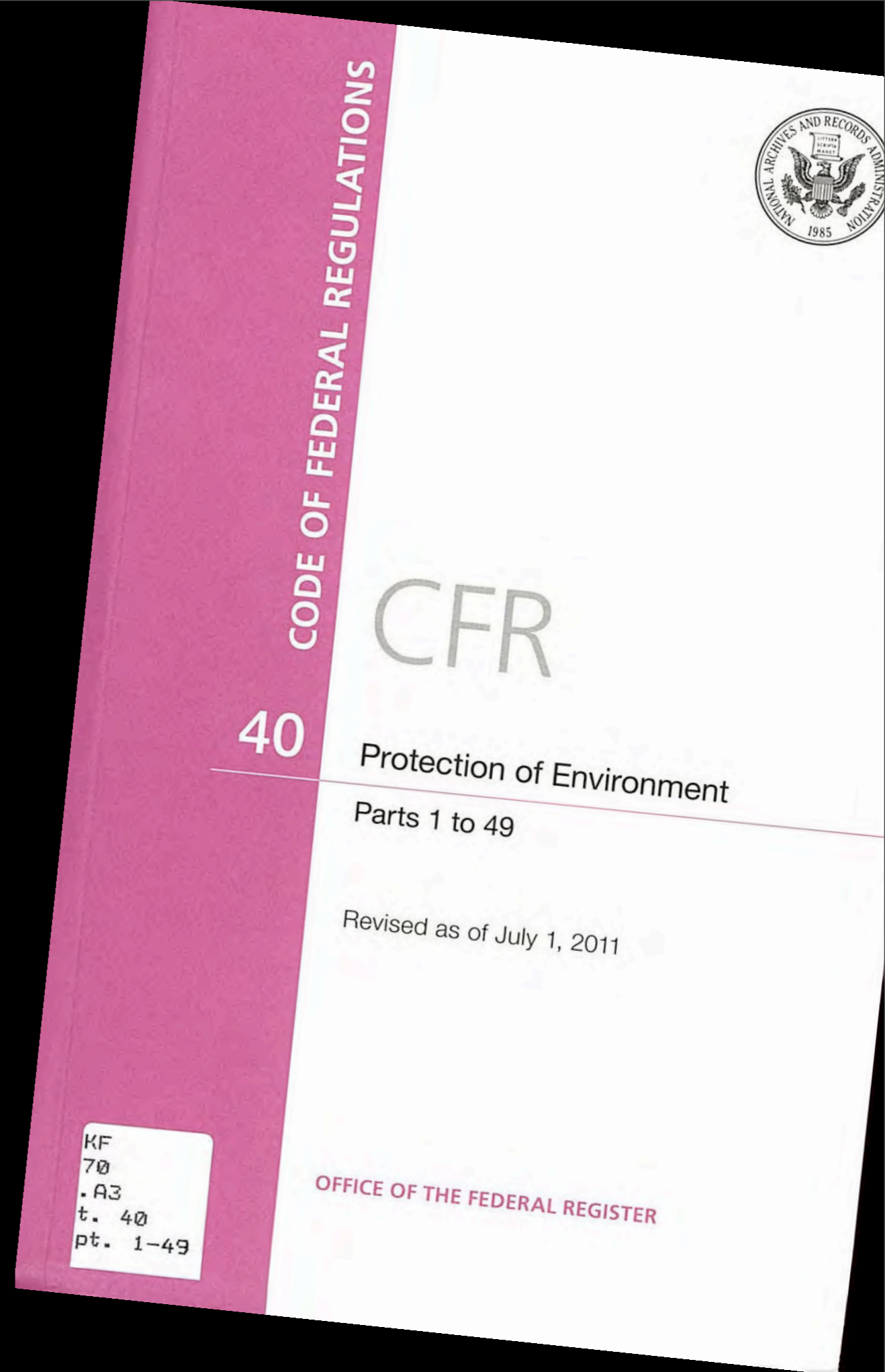

# Monitoring Options

Continuous Emission Monitoring (CEMS)

Periodic Stack Test

Existing Units Only

# Monitoring Options

Continuous Emission Monitoring (CEMS)

Periodic Stack Test

Existing Units Only

# Periodic Monitoring

Issues with stack test methods - M26/26A

Undefined potential biases at very low concentrations

Moisture, SO<sub>2</sub>, Bromine

LOQ for methods may be higher than  
emission limit

CleanAir conducting EPRI study of M26/26A  
to answer these questions

# Periodic Monitoring

Stack testing with CEMS

Can perform stack testing with HCl CEMS

Same issues as with permanently installed CEMS

# Periodic Monitoring

## Estimated Stack Test Costs

Test	Approximate Cost
HCI/HF (M26, M26A)	\$7,600 - 11,400
HCI (FTIR)	\$15,200 - 23,400
HCI CEMS RATA	\$9,200 - \$13,800

Note: Prices are for individual tests at a single location assuming no delays. Simultaneous testing with multiple methods may reduce overall costs. Actual testing costs will vary from these estimates based on site-specific conditions, variable travel costs, and current market conditions.

# MATS Rule Monitoring Workshop

Presented by RMB Consulting & Research

Lake Tahoe, Nevada  
September 19, 2013

Memphis, Tennessee  
October 3, 2013





®

*CleanAir*®

ENGINEERING

[sevans@cleanair.com](mailto:sevans@cleanair.com)